

A B C D E F G

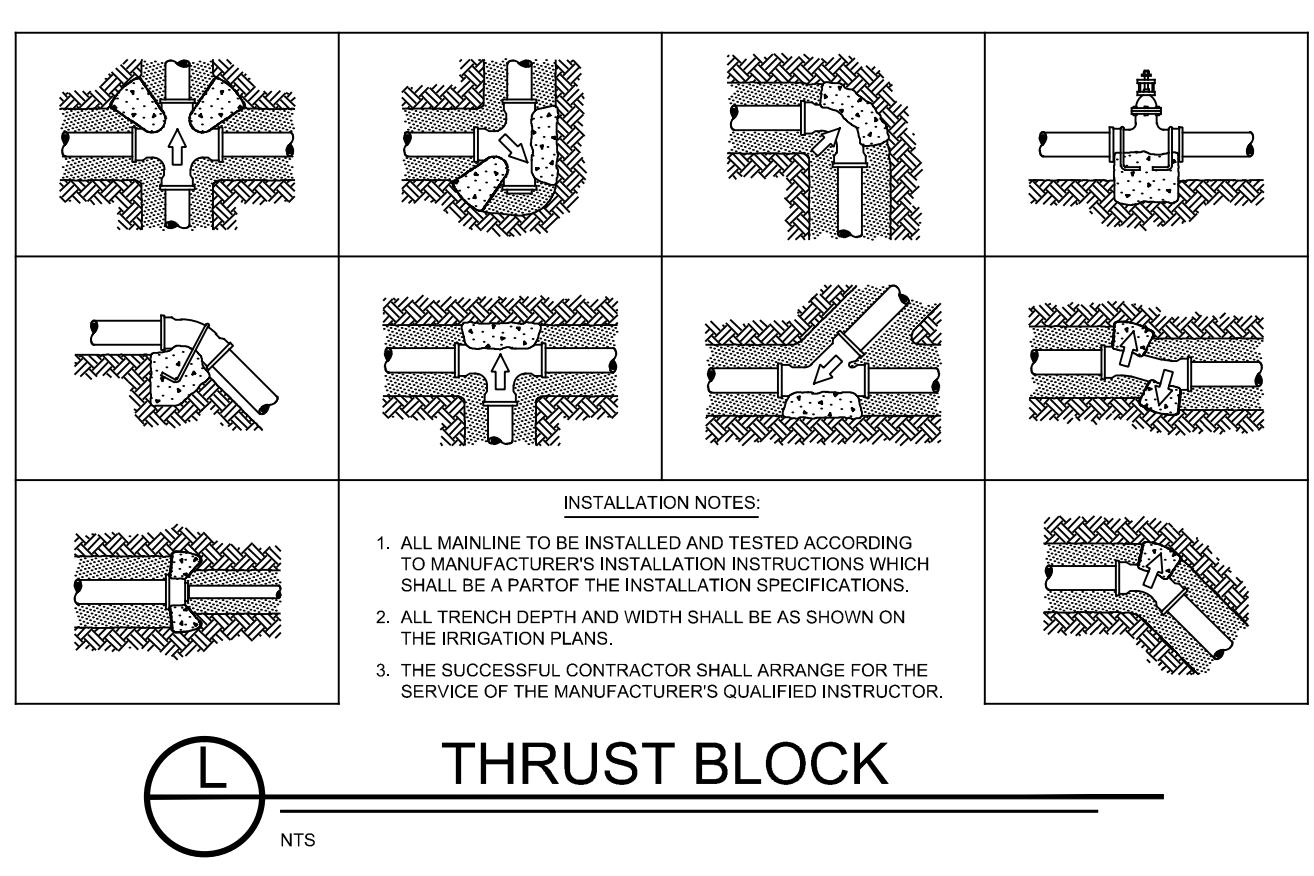
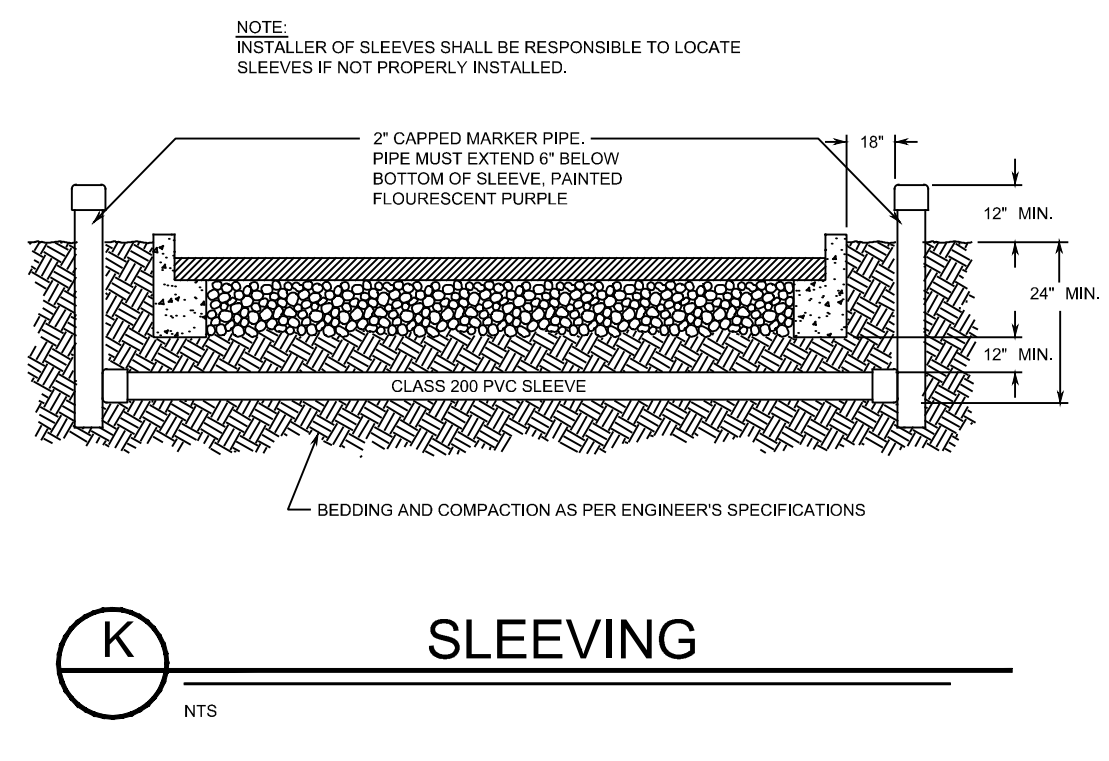
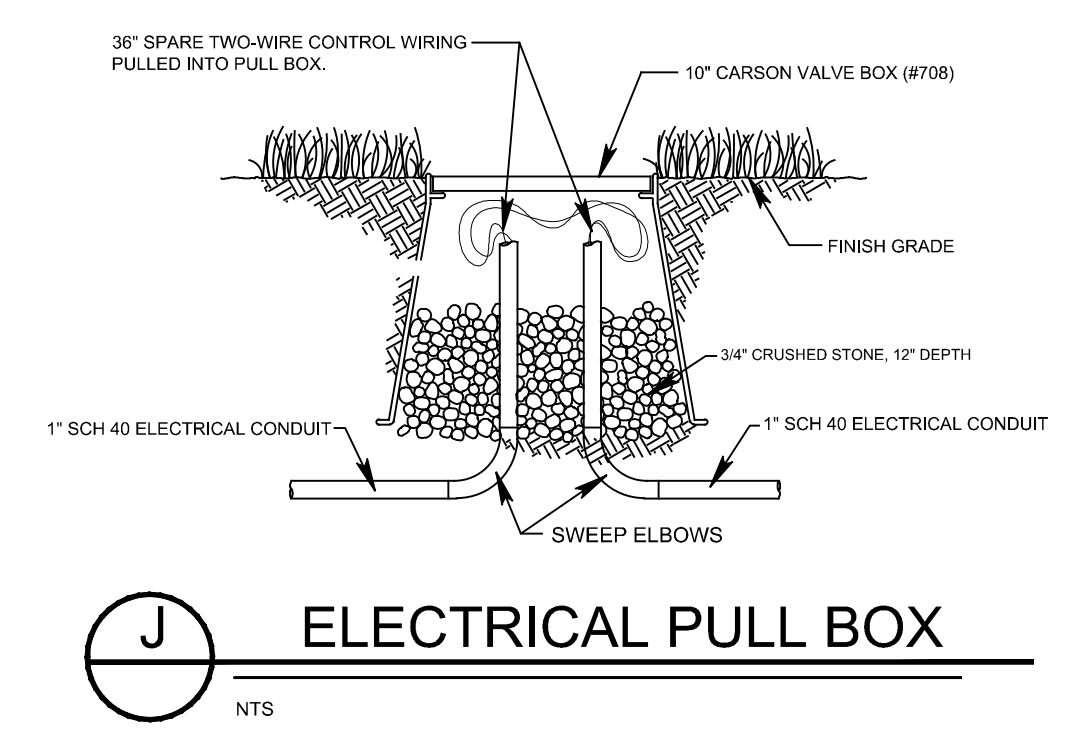
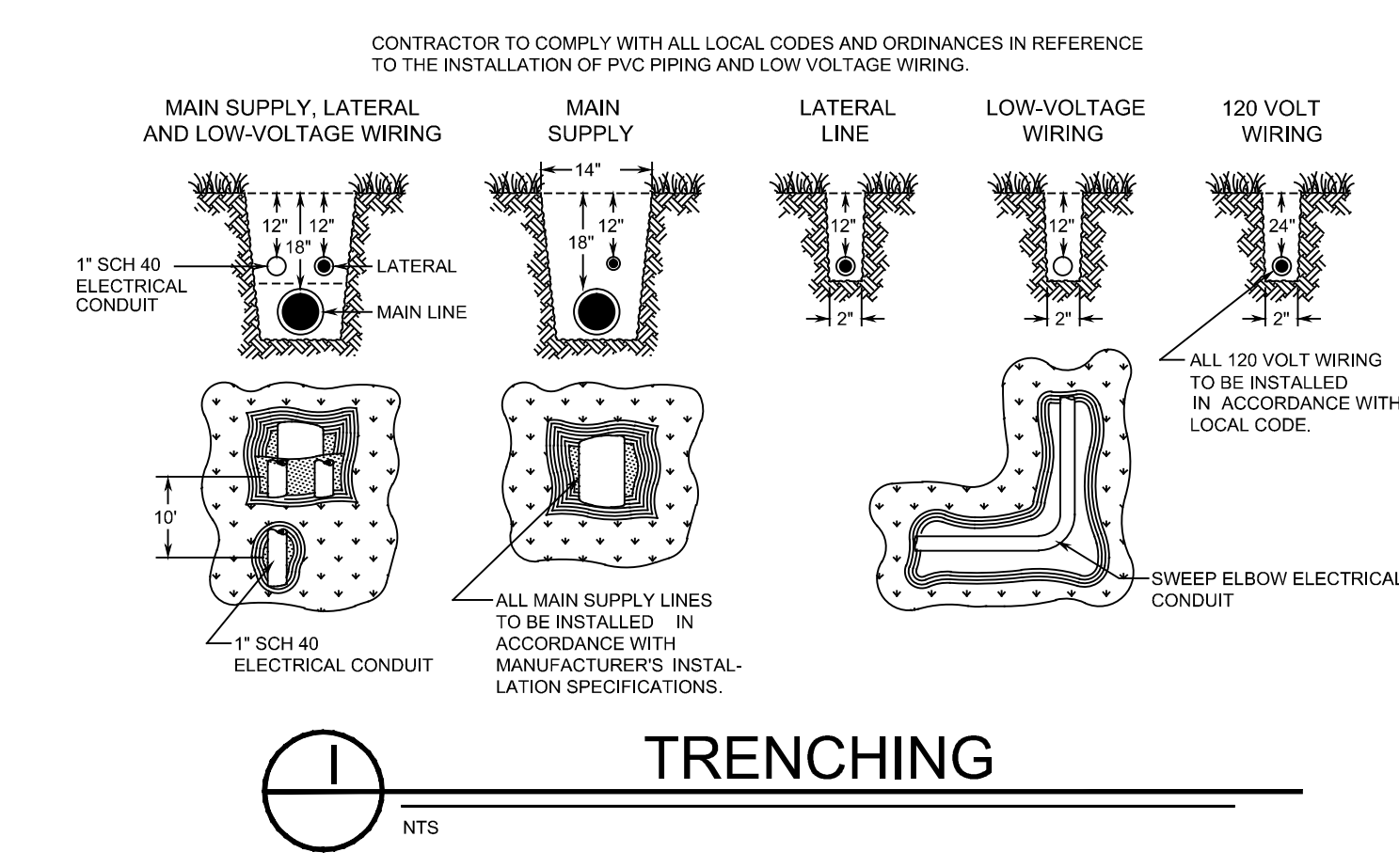
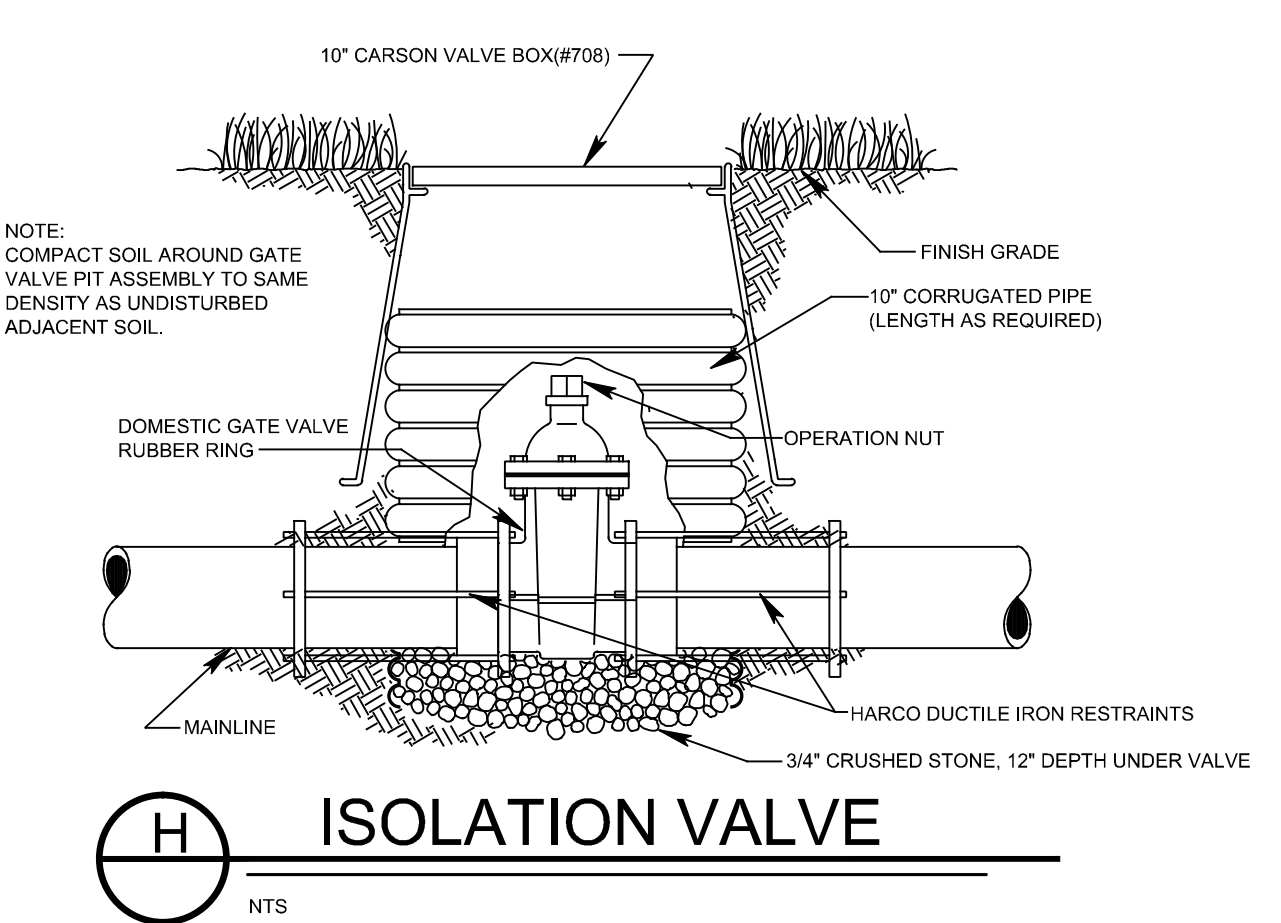
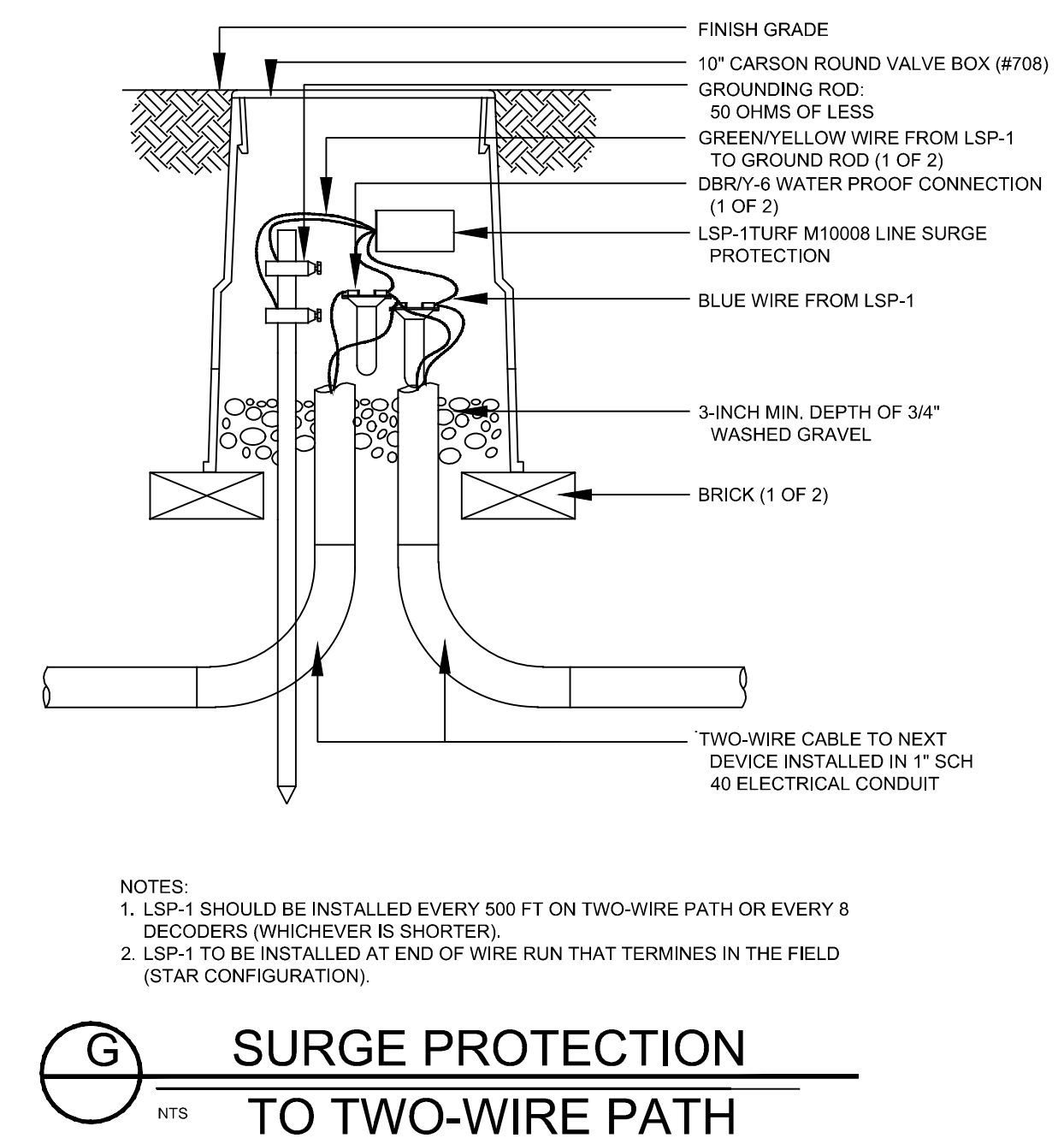
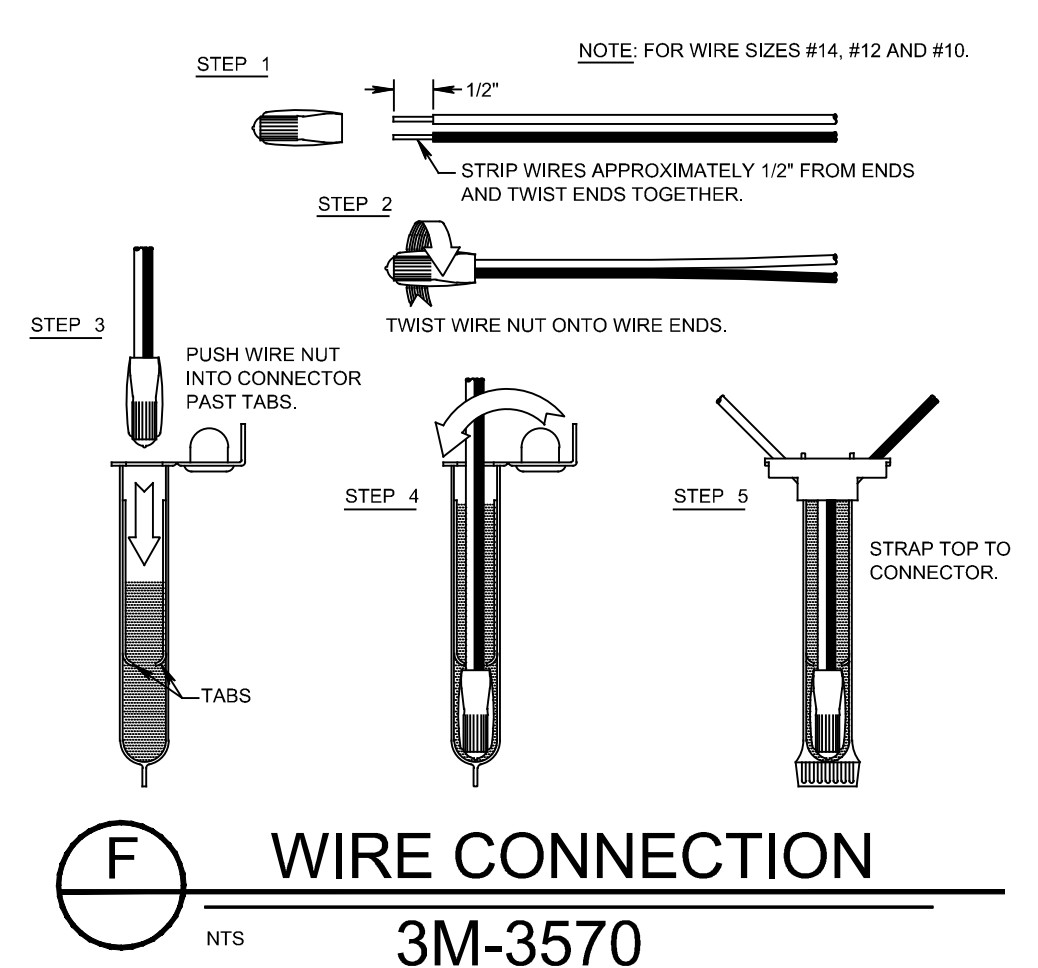
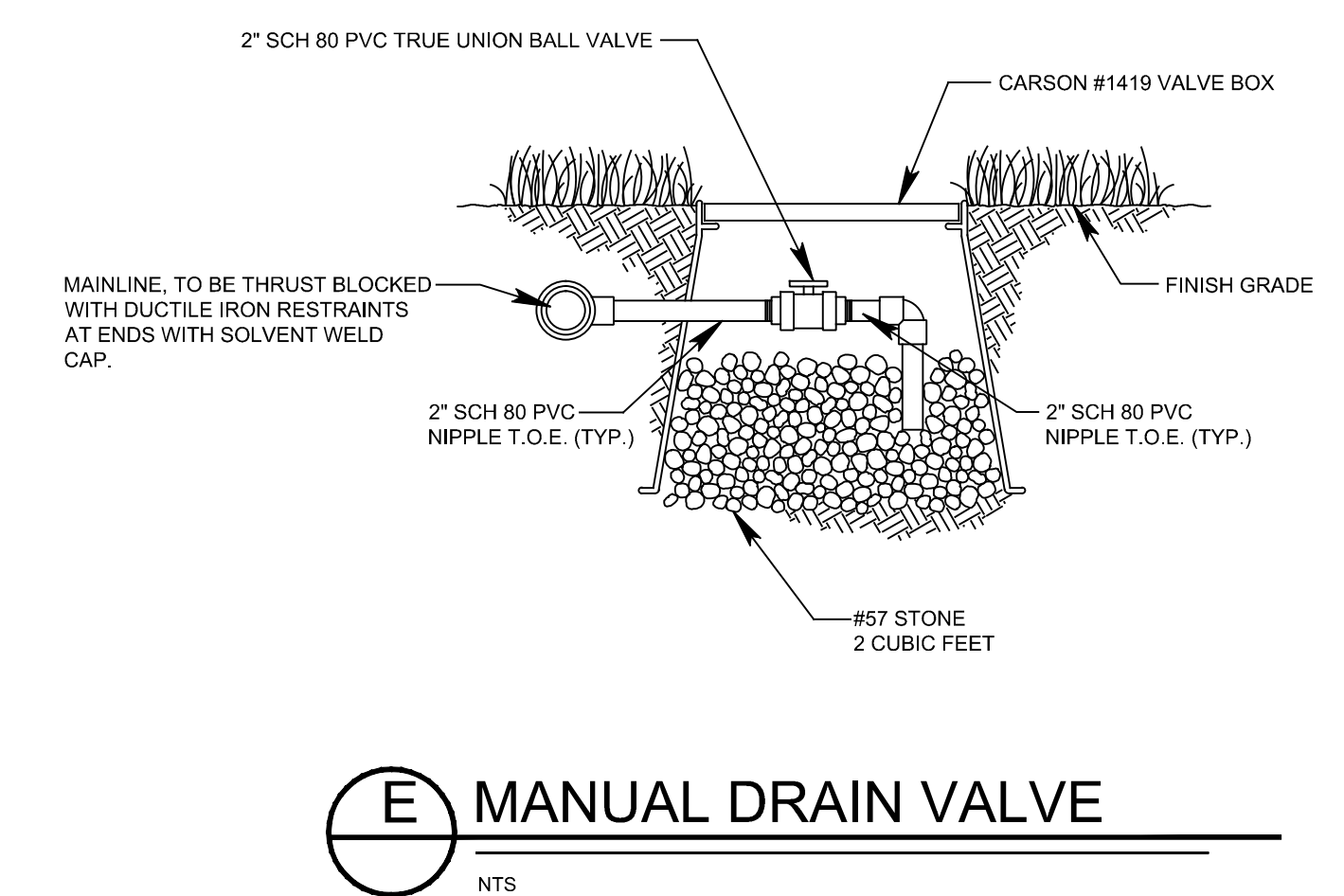
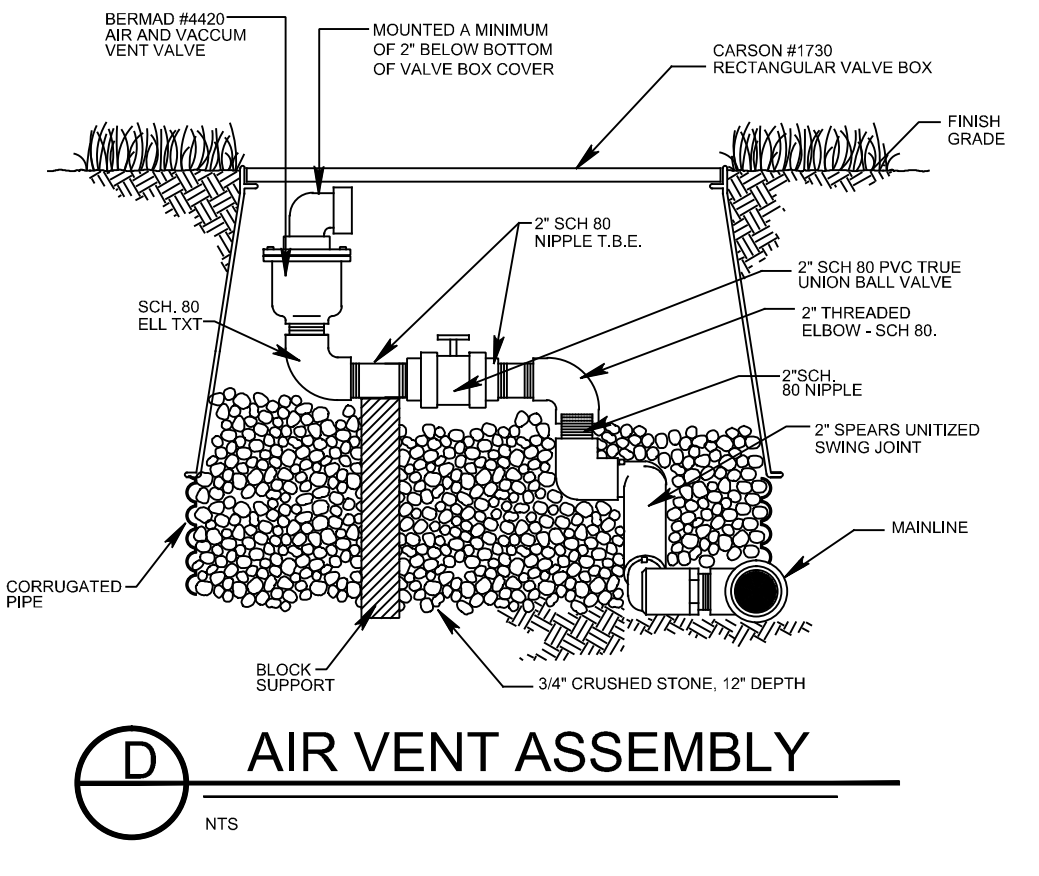
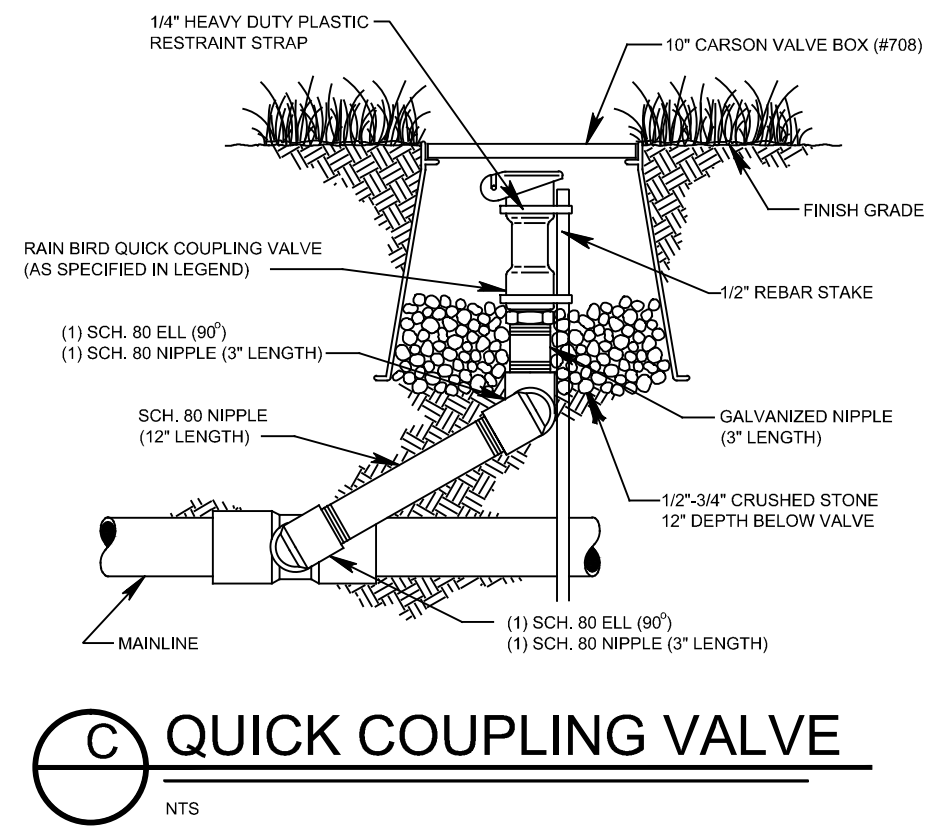
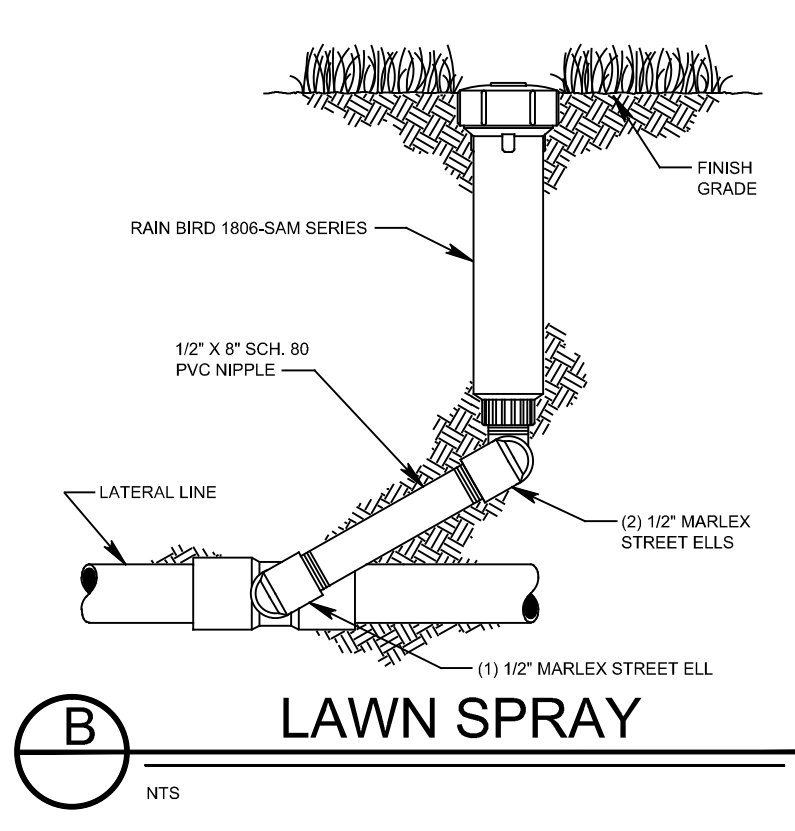
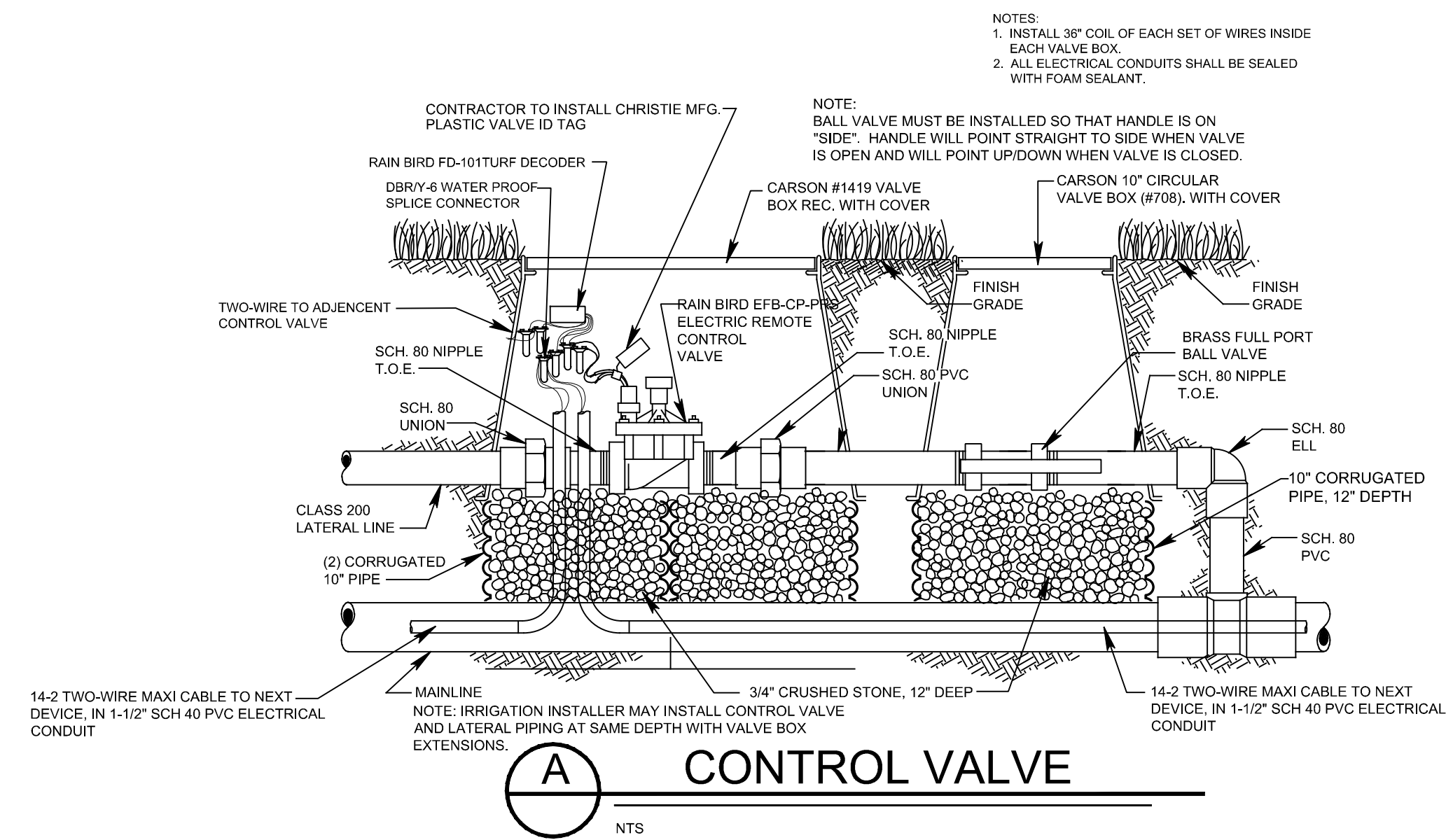

NO.	DATE	DESCRIPTION	BY
0			
1			
2			
3			
4			
5			

4317 Park Drive, Suite 400  
Norcross, Georgia 30093  
Phone: (770)416-7511  
Fax: (770)416-6759  
www.travispruitt.com  
Contact Person:

Travis Pruitt & Associates, Inc.  
Irrigation • Landscape • Landmark

IRRIGATION DETAILS

# FREEDOM PARK PHASE 3

MACON, GEORGIA